

Resolution 2026-R-12

A Resolution accepting the Bid for the Water Main Extension Materials at the Irondale Civic Center and Authorizing the Mayor to Execute Documents Related Thereto

WHEREAS, the invitation to bid for the Water Main Extension at Irondale Civic Center was prepared in compliance with the provisions of the Alabama Bid Law; and

WHEREAS, the City of Irondale publicly opened and read aloud the Project bids that were submitted, as shown in the table below:

COMPANY	TOTAL BID PRICE
Southern Pipe & Supply	\$313,806.81
Empire Pipe & Supply	\$315,302.05
Core & Main	\$339,996.00
Consolidated Pipe & Supply Co., Inc.	\$322,483.04

THEREFORE BE IT RESOLVED by the City Council of the City of Irondale, Alabama, in regular meeting duly assembled, a quorum being present as follows:

1. The bid for the water main extension at the Irondale Civic Center in the total amount of Three Hundred Fifteen Thousand Three Hundred Two and 05/100 Dollars (\$315,302.05) is hereby accepted as the lowest responsive bid.
2. Mayor James D. Stewart, Jr., or his designee, is hereby authorized to execute any necessary documents with Empire Pipe & Supply, Inc. for such amount not to exceed \$315,302.05 to effectuate this bid acceptance.

ADOPTED & APPROVED: This 20th day of January, 2026.



David Spivey, City Council President

APPROVED:

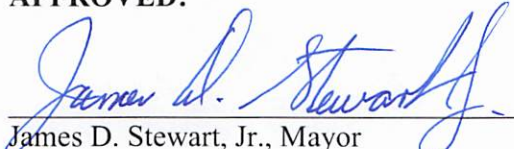

James D. Stewart, Jr., Mayor

ATTESTED:

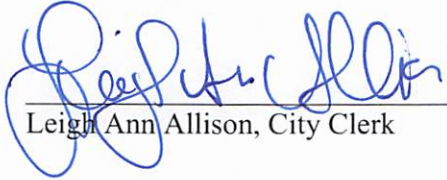

Leigh Ann Allison, City Clerk

CERTIFICATION

I, Leigh Ann Allison, the City Clerk of the City of Irondale, Alabama, hereby certify that the above to be a true and correct copy of a resolution adopted by the City Council of the City of Irondale at its regular meeting held on January 20, 2026, as the same appears in the minutes of record of said meeting.

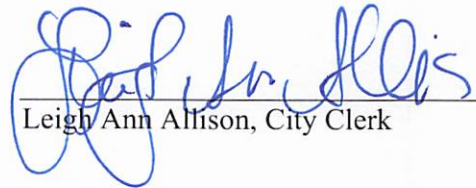

Leigh Ann Allison, City Clerk

Empire Pipe Supply

Irondale Water
Bid - Civic Center Water Main Extension
Jan. 15 2026 10:00 A.M.

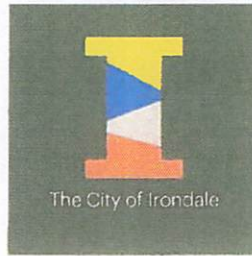

ADVERTISEMENT FOR BIDS

Sealed proposals for the construction of the Civic Center Water Main Extension will be received by the City of Irondale, Alabama (“Owner”) in the Council Chambers at the City Hall in Irondale, Alabama at 101 20th Street South, Irondale, Alabama, until **10:00 a.m.**, the prevailing time on **January 15, 2026** or by mailing to 101 20th Street South, Irondale, Alabama 35210 at which time and place they will be publicly opened and read. The bid is comprised of the following:

1300 L.F. ± of 12” ductile iron pipe and appurtenances

3,200 L.F. ± of 8” joint ductile iron pipe and appurtenances

Plans and specifications may be received at the Irondale Water Department located at 1801 Crestwood Blvd, Irondale, AL 35210, or by emailing jmorris@cityofirondaleal.gov.

All Bidders must be responsible and meet the criteria, requirements, and applicable 30-day delivery timeframe once the P.O. is issued.

This project is considered a “Public Works” project and is governed by bid laws as contained in Title 39 of the Alabama Code. Bidders, subcontractors, suppliers, and Bond Agents should be familiar with this code.

The Owner reserves the right to reject any or all proposals and to waive any informalities. No Bidder may withdraw his bid within fourteen (14) days from the date set for receiving of the same. There will not be a Pre-Bid Conference.

This project is governed by the applicable bid laws and practices of the state of Alabama.

By: Leigh Ann Allison

Title: City Clerk

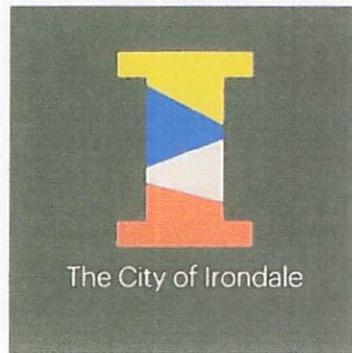

STATE OF ALABAMA
COUNTY OF JEFFERSON

Invitation to Bid
Civic Center Water Main Extension Materials

Sealed bids will be received by the City of Irondale, Alabama for the Irondale Water Department at Irondale City Hall, 101 20th Street South, Irondale, Alabama 35210 until 10:00 a.m. local time on January 15, 2026, at which time bids will be opened publicly and read in the City Council Chambers. The City reserves the right to reject any or all bids and to waive informalities in awarding this bid to the lowest responsive bidder. Bidders are to state that bids submitted are firm and that no claims for errors will be made after bids are opened and subsequent thereof. If you have questions concerning this bid, contact Jared Morris in writing at jmorris@cityofirondaleal.gov.

GENERAL INFORMATION

All bidders must use the form provided in the bid package for submitting their bids. All bids must be sealed and marked in the lower left corner "BID – Civic Center Water Main Extension Materials". Late bids will not be opened.

Records showing successful bidder(s) and prices quoted will be placed on file and may be examined upon request.

Should there be a change in ownership or management, the agreement may be canceled at the City's discretion unless a mutual agreement is reached with the new owner or manager to continue the agreement with its present provisions and prices. The agreement is not transferable by either party.

METHOD OF AWARD

The award will be made to the lowest bidder meeting specifications. It is not the policy of the City to purchase on the basis of low bid only. Quality, conformity with the specifications, terms of delivery and past service and experience are among the factors that may be considered in determining the responsive bidder.

CONTRACT PERIOD

This contract will discharge upon payment and delivery of materials.

LAWS and ORDINANCES

The supplier shall observe and comply with all federal, state, local and municipal laws, ordinances, rules and regulations that would apply to this contract.

Leigh Ann Allison
City Clerk

BID QUOTATION SHEET
City of Irondale, Alabama

	DESCRIPTION	QUANTITY	UNIT PRICE	TOTAL	DELIVERY LEAD TIME	
1.	12" D.I.Slip Joint Class 350	1300'	54.77	71,201.00	2-3 weeks	
2.	12" D.I.MJ Sleeve	2	349.23	698.46	7-10 days	
3.	12" D.I.MJ 45 Degree Bend	10	379.14	3791.40	↓	
4.	12" D.I.MJ 22-1/2 Degree Bend	12	330.91	3970.92		
5.	12" D.I.MJ 11-1/4 Degree Bend	12	310.76	3729.12		
6.	12" x 12" D.I.MJ Tee	2	635.56	1271.12		
7.	12" x 6" D.I. Swivel Tee	1	442.64	442.64		
8.	12" x 3" D.I. MJ Tee	1	460.95	460.95		
9.	12" D.I. Anchor Coupling Swivel x Solid (13" Long)	3	816.89	2450.67		
10.	12" D.I. MJ R.S. AWWA C-515 Gate Valves	3	2815.20	8445.60		3 weeks
11.	12" x 8" D.I. MJ Reducer	1	216.74	216.74		
12.	12" D.I. MJ Gasket and Bolt Pack	12	42.74	512.88		
13.	12" D.I. Pipe Megalugs w/ Glands, Bolts, Gaskets	80	126.95	10,156.00		
14.	8" D.I.Slip Joint Class 350	3200'	35.75	114,400.00		2-3 weeks
15.	8" D.I.MJ Sleeve	4	216.74	866.96		7-10 days
16.	8" D.I.MJ 45 Degree Bend	2	176.45	352.90	↓	
17.	8" D.I.MJ 22-1/2 Degree Bend	20	171.56	3431.20		
18.	8" D.I.MJ 11-1/4 Degree Bend	8	155.69	1245.52		
19.	8" x 12" D.I.MJ Tee	8	496.36	3970.88		
20.	8" x 6" D.I. Swivel Tee	4	308.32	1233.28		
21.	8" D.I. Anchor Coupling Swivel x Solid (13" Long)	6	310.76	1864.56		
22.	8" D.I. MJ R.S. AWWA C-515 Gate Valves	6	1426.80	8560.80		
23.	8" x 6" D.I. MJ Reducer	2	126.38	252.76		

24.	8" x 12" D.I. MJ Cross	1	601.37	601.37	8-10 days
25.	8" D.I. Pipe Megalugs w/ Glands, Bolts, Gaskets	90	66.70	6003.00	↓
26.	8" D.I. MJ Gasket and Bolt Pack	50	31.75	1587.50	
27.	8" D.I. MJ Plug w/ 2" MIP Tap	4	153.86	615.44	
28.	6" D.I. MJ Sleeve	2	135.54	271.08	
29.	6" D.I. MJ R.S. AWWA C-515 Gate Valves	5	895.80	4479.00	7-10 days
30.	6" D.I. Anchor Coupling Swivel x Solid (24" Long)	5	360.83	1804.15	↓
31.	6" Fire Hydrant (4' Bury) (5.25" barrel) - M&H with Storz.	5	2953.77	14,768.85	
32.	6" D.I. Pipe Megalugs w/ Glands, Bolts, Gaskets	4	48.89	195.56	
33.	6" PVC Pipe Megalugs w/ Glands, Bolts, Gaskets	4	31.75	127.00	
34.	6" D.I. MJ Gasket and Bolt Pack	30	28.09	842.70	↓
35.	3" D.I. MJ R.S. AWWA C-515 Gate Valves	2	628.20	1256.40	3 days
36.	3" D.I. MJ Tee	2	112.34	224.68	7-10 days
37.	3" D.I. MJ Plug with 2" FIP	4	84.26	337.04	↓
38.	3" D.I. Anchor Coupling Swivel x Solid (13" Long)	2	83.11	166.22	
39.	2" x 4" SS Nipple	8	21.48	171.84	
40.	2" SS 90° FIP x FIP	6	21.63	129.78	
41.	2" Rehau Municipex (100' Roll)	5	9.57	4785.00	10-12 days
42.	12 Gauge Tracer Wire (500' Roll)	1	70.00	70.00	In stock
43.	2" D.I. Threaded R.S. AWWA C- 515 Gate Valves	4	428.40	1713.60	3 days
44.	2" Male Adapter CTS PJ	10	96.77	967.70	7-10 days
45.	2" Female Adapter CTS PJ	10	103.40	1034.00	↓
46.	2" SS Inserts	25	2.50	62.50	
47.	2" Meter Vault (See Attached Detail)	3	6600.00	19,800.00	3 days
48.	3" Meter Vault (See Attached Detail)	1	6000.00 6200.00	6200.00	3 days

49.	Precast Circular 18" Concrete Valve Donut	4	31.12	124.48	10-12 days
50.	Cast Iron Valve Box and Lid Marked "WATER" (24"-36" Depth)	30	95.56	2866.80	↓
51.	Concrete Waterline Markers	12	47.50	570.00	↓

TOTAL: 315,302.05

Notes:

1. D.I. shall only be American, U.S. Pipe or Mcwane.
2. Hydrants shall be M&H with Storz Connections.
3. Gate valves shall be M&H.
4. Import fittings will be accepted.

IF UNDERSIGNED IS THE SUCCESSFUL BIDDER, THE OWNER SHALL NOTIFY THE SUPPLIER IN WRITING WITHIN 14 DAYS OF BID OPENING. THE TOTAL PAYMENT SHALL BE DUE NET 30 AFTER DELIVERY OF MATERIALS.

THE UNDERSIGNED UNDERSTANDS AND AGREES TO A 30-DAY DELIVERY FOLLOWING THE ISSUANCE OF A P.O. BY OWNER TO THE SUCCESSFUL BIDDER.

THE UNDERSIGNED OFFERS THESE PRICES, TERMS, AND DELIVERY AS PER BID GENERAL CONDITIONS AND SPECIFICATIONS. BIDS SUBMITTED ARE FIRM AND NO CLAIMS FOR ERRORS WILL BE MADE AFTER BIDS ARE OPENED.

NAME OF COMPANY: Empire Pipe Supply

BY: Cody Grant
(Please Print)

SIGNATURE (Authorized Representative): *Cody Grant*

COMPANY ADDRESS: ~~2301~~ 2301 Alton Road
Birmingham, Al 35210

PHONE: 334.436.0180

E-MAIL: Cody@empirepipe.com

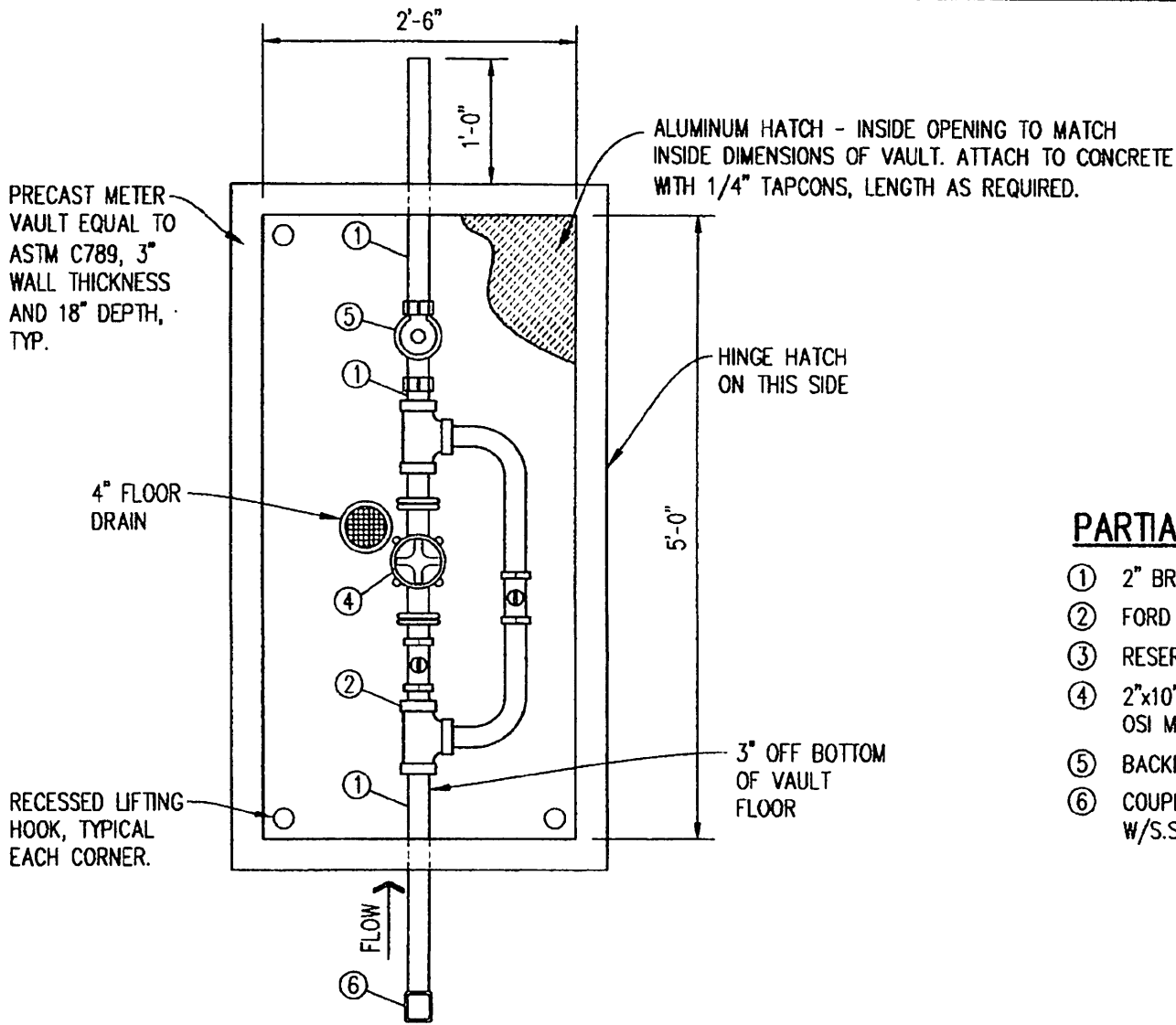

PARTIAL MATERIAL LIST

- ① 2" BRASS NIPPLE, LENGTH AS REQ'D.
- ② FORD METER SETTER, VBB77-00B-41-77-NL
- ③ RESERVED
- ④ 2"x10" SS MASTER METER OCTAVE WITH OSI MODULE AND 3G ENABLED XTR
- ⑤ BACKFLOW PREVENTER, FORD HHS11-777-NL
- ⑥ COUPLING ADAPTER, FORD CB4-77-NL W/S.S. STIFFENER

2" METER VAULT

SCALE: 3/4"=1'-0"

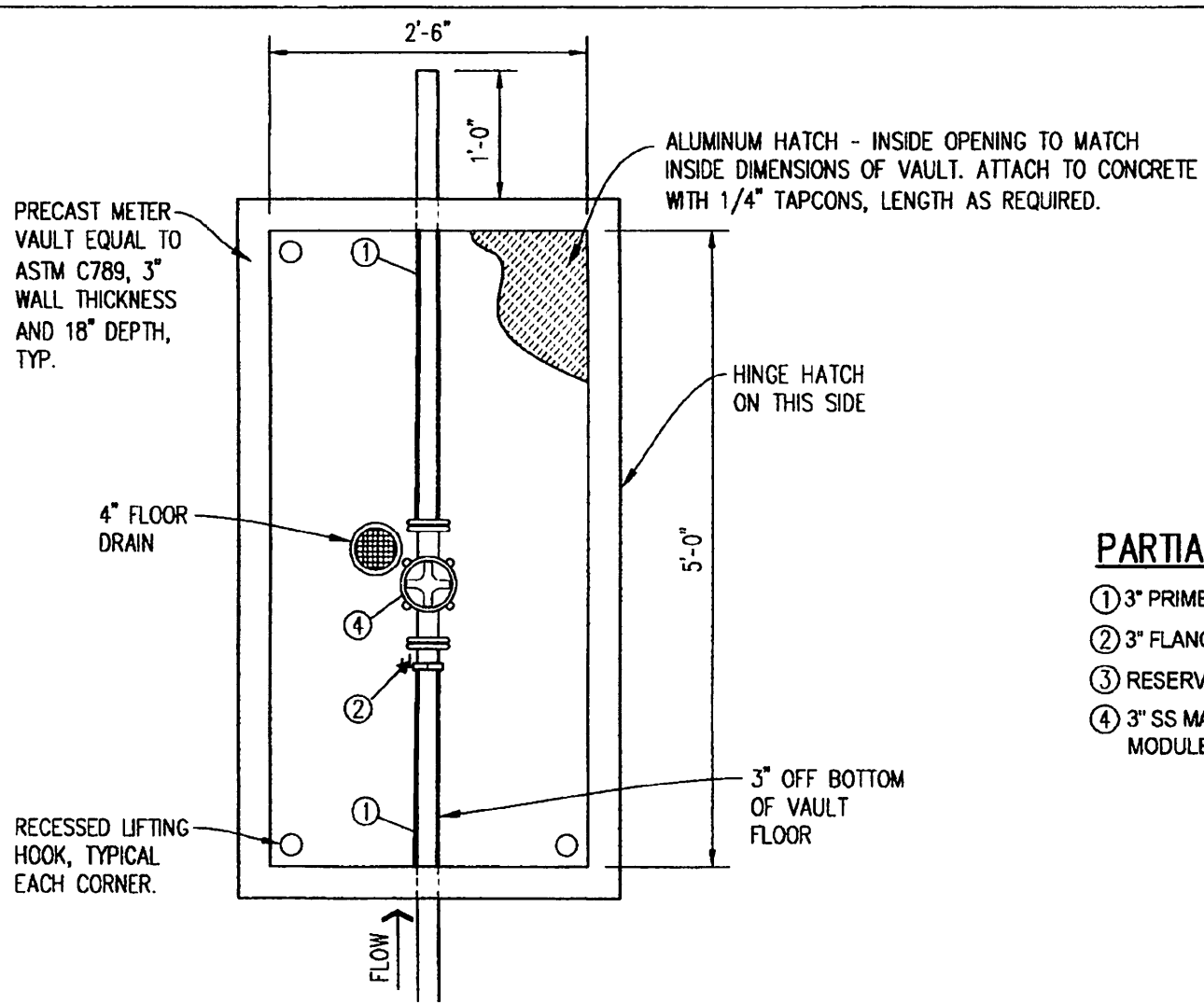

PARTIAL MATERIAL LIST

- ① 3" PRIMED D.I. SPOOL PIECE, LENGTH AS REQ'D
- ② 3" FLANGE ADAPTER, STAR 3200 SERIES W/ MEGA LUGS
- ③ RESERVED
- ④ 3" SS MASTER METER OCTAVE WITH 4G ALLEGRO MODULE

3" METER VAULT

SCALE: 3/4"=1'-0"